

A Dissipative Algorithm for Wave-like Equations in the Characteristic Formulation

Luis Lehner

University of Pittsburgh, Pittsburgh, Pennsylvania 15260; and The University of Texas at Austin, Austin, Texas 78712

E-mail: luisl@raven.phyast.pitt.edu, luisl@feynman.ph.utexas.edu

Received April 30, 1998; revised October 9, 1998

We present a dissipative algorithm for solving nonlinear wave-like equations when the initial data is specified on characteristic surfaces. The dissipative properties built in this algorithm make it particularly useful when studying the highly nonlinear regime where previous methods have failed to give a stable evolution in three dimensions. The algorithm presented in this work is directly applicable to hyperbolic systems proper of electromagnetism, Yang–Mills, and general relativity theories. We carry out an analysis of the stability of the algorithm and test its properties with linear waves propagating on a Minkowski background and the scattering off a Schwarzschild black hole in general relativity. © 1999 Academic Press

Key Words: derivation of finite difference approximations; stability and convergence of difference methods; electromagnetism, other.

I. INTRODUCTION

When modeling nonlinear problems, dissipative algorithms have provided researchers with an extremely valuable tool since usually most nondissipative schemes fail to produce a stable evolution. More precisely, when using neutrally stable algorithms, instabilities often arise which spoil the evolution. The addition of artificial dissipation removes these instabilities by “damping” the growing modes of the solution in a somewhat controlled way. Therefore, its inclusion in a discretization scheme provides a practical and economical way of achieving longer evolutions.

The most widely used algorithms with this property are the family of Lax schemes [1], whereby adding to the equation $u_{,t} = -au_{,x}$ a term proportional to $u_{,xx}$ one obtains a stable discretization of the system that would otherwise be unstable. However, one might correctly ask whether this is not tantamount to solving a completely different problem. The beauty of these methods is that the proportionality factor depends on the discretization size,

and in the continuous limit the approximation to the modified PDE results in a consistent approximation to the original one.

Although there is much experience with these kinds of schemes, most of the standard dissipative algorithms have been tailored for Cauchy initial value problems, where initial data is provided at one instant of time and evolved to the next instant by means of the evolution equation. However, in radiative problems, it is sometimes more convenient to choose a sequence of hypersurfaces adapted to the propagation of the waves, and therefore, one adopts a foliation adapted to the characteristics of the PDE under study.

In the present work, we present a new algorithm adequate for hyperbolic systems. The underlying strategy of the proposed algorithm is quite different from the conventional Cauchy-type methods. Rather, it is inspired by analytical concepts developed in the 1960s [2–4] for studies of gravitational radiation in general relativity and in their subsequent numerical integrations.¹ The main features of this approach are the use of characteristic surfaces (for the foliation of the spacetime) and compactification methods (that enable the inclusion of infinity in the numerical grid) to describe radiation properties. Although evolution algorithms (for systems possessing some kind of symmetry) developed within this approach proved to be successful in the linear and mildly nonlinear regime [6–8], they produce unstable evolutions when applied to the general case, which shows the need for devising algorithms that could be applied in this situation. In the present work we present a new algorithm having dissipative properties, making it a valuable tool to study systems where strong fields might be present.

In Section 2 the details of the algorithm for the wave equation are presented and its stability properties discussed. Section 3 is devoted to treat a model problem which shows how the dissipative algorithm might be a useful tool for numerical investigations in general relativity. Finally, in Section 4 we describe two particular applications of this algorithm in the numerical implementation of general relativity.

II. THE ALGORITHM

Waves of amplitude g traveling in one spatial direction with unit speed obey the familiar equation

$$g_{,tt} - g_{,xx} = 0 \tag{1}$$

which can be solved in the region $R = \{(t, x)/t \geq t_0, x \in \mathbb{R}\}$, assuming $g(t = t_0, x)$ and $g_{,t}(t = t_0, x)$ are given. If, instead, one is interested in solving the problem restricted to the region $x \in [a, \infty)$, boundary data must also be provided corresponding to $g(t, x = a)$. The analysis of this problem can be described in a simple way in terms of the characteristics of this equation, which are given by $(x - x_o) = \pm t$ through each spatial point x_o .

In particular, when solving Eq. (1) in the region \mathcal{R}_C . The domain of dependence \mathcal{D}_C of a point (t_1, x_1) is given by $\mathcal{D}_C = \mathcal{S}_C \cap \mathcal{R}_C$, with \mathcal{S}_C naturally defined by the characteristics passing through (t_1, x_1) as

$$\mathcal{S}_C = \{(t, x) \text{ such that } t \leq t_1 \text{ and } (t - t_1)^2 - (x - x_1)^2 \geq 0\}; \tag{2}$$

¹ For a detailed account of the developments in the characteristic formulation see [5].

\mathcal{R}_c is the region to the future of

- the line $t = t_0$, or
- the region defined by $[a, \infty)$ or $x \in [a, b]$ (where $a \in \mathbb{R}$). In these cases, boundary conditions must be imposed at $x = a$ (and $x = b$ in the latter case).

Suppose one introduces a coordinate system adapted to the characteristics by, say ($u = t - x$, $r = x$); then, Eq. (1) reduces to

$$2g_{,ur} - g_{,rr} = 0. \quad (3)$$

Further, one can then choose to foliate the spacetime by a sequence of characteristics obtained by holding the (retarded) time $u = \text{const}$. One can then define a *characteristic initial value problem*, where Eq. (3) is solved, provided that $g(u = u_o, r)$ is given. (Note that $g_{,u}(u = u_o, r)$ need not be provided as in the Cauchy initial value problem).

It is straightforward to check that a solution of Eq. (3) is expressible as $g(u, r) = F(u) + G(u + 2r)$ (where F and G are smooth functions). Physically, $F(u)$ describes waves propagating in the $+r$ direction (outgoing waves) and $G(u + 2r)$ describes waves propagating in the $-r$ direction (incoming waves). Then, if one imposes the condition of pure outgoing waves, the solution must be of the form $g = F(u)$; hence, along each characteristic the value of the function is constant. Notably, boundary data at $r = 0$ can be given arbitrarily since purely outgoing waves at $u = u_0$ will not reach $r = 0$. More generally, boundary data consistent with the incoming waves must be prescribed at $r = 0$.

It is important to note the domain of dependence for this problem. When solving Eq. (3) in the region \mathcal{R}_c , the domain of dependence (\mathcal{D}_c) of a point (u_1, r_1) is defined by $\mathcal{D}_c = \mathcal{S}_c \cap \mathcal{R}_c$, where

$$\mathcal{S}_c = \{(u, x) \text{ such that } u \leq u_1 \text{ and } (u - u_1)^2 + 2(u - u_1)(r - r_1) \geq 0\}. \quad (4)$$

However, if the region \mathcal{R}_c is chosen to be the future of the line $u = u_0$, \mathcal{D}_c extends indefinitely to the past. Therefore, the characteristic approach requires \mathcal{R}_c to have a boundary. Thus, one defines \mathcal{R}_c as the region ($u \geq u_o$, $r \in [a, \infty)$) (with $a \geq 0$). Figure 1 illustrates the domains of dependence corresponding to each formulation.

For hyperbolic systems with two or more spatial dimensions, the manner in which the characteristics determine the domain of dependence and lead to evolution equations is qualitatively the same. Also, the use of coordinates adapted to them provide a tidy way for studying the system. For instance, in three dimensions, the wave equation is given by

$$\Psi_{,tt} - \Psi_{,xx} - \Psi_{,yy} - \Psi_{,zz} = 0, \quad (5)$$

which, in term of spherical polar coordinates (t, r, θ, ϕ) has the form

$$r\Psi_{,tt} - (r\Psi)_{,rr} - L^2\Psi/r = 0, \quad (6)$$

where L^2 denotes the angular momentum operator

$$L^2\Psi = \frac{(\sin(\theta)\Psi_{,\theta})_{,\theta}}{\sin(\theta)} + \frac{\Psi_{,\theta\theta}}{\sin^2(\theta)}. \quad (7)$$

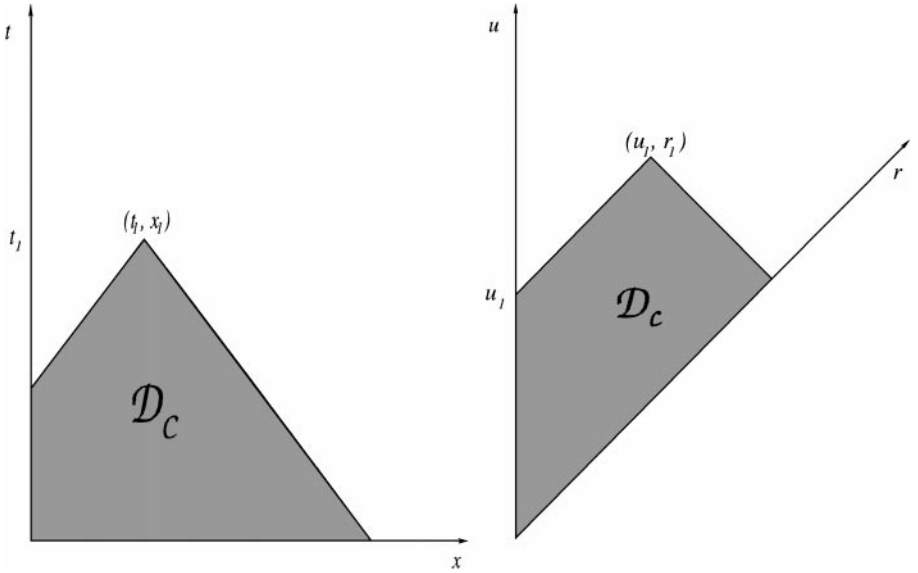

FIG. 1. Domains of dependence in the Cauchy and characteristic initial value problems.

Introducing coordinates $(u = t - r, r, \theta, \phi)$ which define a natural inner boundary at $r = 0$, Eq. (6) takes the form

$$2(r\Psi)_{,ur} - (r\Psi)_{,rr} = \frac{L^2\Psi}{r}. \quad (8)$$

Thus, by defining $g \equiv r\Psi$ and considering $L^2\Psi/r$ as a source term, Eq. (8) formally looks like the one-dimensional system. Therefore, from now on we restrict our analysis to this latter case and extend our results to the three-dimensional case in Section 4.

The formal integration of (3) proceeds by an integration in the r direction on each $u = \text{const}$ surface and then evolves to the next level. This reformulates the integration in the characteristic formulation as an “evolution” in the radial direction and then another in the u direction (as opposed to the evolution of a “whole” instant of time to the next one typical of the Cauchy evolution). Hence, standard dissipative schemes intended for Cauchy-type evolutions (like the family of Lax algorithms) are not directly applicable in the characteristic formulation of the PDE and the addition of artificial viscosity to the system must be reformulated.

In the numerical implementation of Eq. (3) a useful discretization was introduced in [9]. This scheme is basically a second-order approximation based on finite difference techniques. Assuming the grid discretization is given by $u_n = n\Delta u$ and $r_i = i\Delta r$, the derivatives may be discretized as

$$g_{ur}|_{i-1/2}^{n+1/2} = \frac{g_i^{n+1} - g_{i-1}^{n+1} - g_i^n + g_{i-1}^n}{\Delta u \Delta r}, \quad (9)$$

$$g_{rr}|_{i-1/2}^{n+1/2} = \frac{g_i^{n+1} - 2g_{i-1}^{n+1} + g_{i-2}^{n+1} + g_{i+1}^n - 2g_i^n + g_{i-1}^n}{\Delta r^2}. \quad (10)$$

The resulting scheme (which we will refer to as GIW) is a second order in time, second

order in space accurate algorithm. Notably, the Von Neuman analysis shows that the GIW scheme has a unitary amplification factor (i.e., a neutrally stable algorithm), independent of the values of Δu and Δr . This would imply that the algorithm is unconditionally stable which is, at first sight, puzzling. This might be explained by the implicit local structure of the algorithm (since it involves three points at the upper time level) and, as such, a local stability analysis need not give a condition on the discretization size. Nevertheless, the algorithm is globally explicit as the evolution proceeds by an outward march from the origin. Hence, the algorithm does require the enforcement of the CFL condition to ensure that the numerical and analytical domains of dependence are consistent.

The CFL condition for the system can be easily obtained. The field at the grid point at (u_1, r_1) depends critically on the field value at $(u_1 - \Delta u, r_1 + \Delta r)$ (since all the points, where $0 \leq r \leq r_1$, are trivially included in the discretization). The requirement for the numerical domain of dependence to include the analytical domain of dependence is $\Delta u^2 - 2\Delta u \Delta r \leq 0$; therefore, the CFL condition will be satisfied if $\Delta u \leq 2\Delta r$.

The GIW algorithm has been employed successfully in the characteristic formulation of general relativity (G.R.) assuming either spherical symmetry [9, 10], axisymmetry [6], or very small departures from spherical symmetry [7]. However, when considering more general problems, as is often the case with neutrally stable schemes, roundoff error or parasitic modes are enough to cause ripples in the solution which often lead to an unstable evolution. As stated earlier, adding dissipation to the PDE constitutes a way to alleviate this problem [1]. We now show that a rather simple modification of (3) can be used to obtain a consistent discretization with dissipative properties.

We start by considering the equation

$$2g_{,ur} - g_{,rr} + 4/3\epsilon \frac{\Delta r^2}{2\Delta u} g_{,rrr} = 0 \quad (11)$$

(the $4/3$ factor is included for convenience). A straightforward discretization of (11) is obtained by the described approximation for $g_{,ur}$ (9) and $g_{,rr}$ (10) and by approximating the third derivative at the point $(n, i - 1/2)$ as

$$g_{,rrr}|_{i-1/2}^n = \frac{1}{\Delta r^3} (g_{i+1}^n - 3g_i^n + 3g_{i-1}^n - g_{i-2}^n). \quad (12)$$

In analogy to the Lax method, the inclusion of this extra term leads to a consistent difference approximation of Eq. (3); this is, the difference approximation converges formally to the differential equation in the limit $(\Delta u, \Delta r) \rightarrow 0$. In fact, it is straightforward to check that the resulting approximation is accurate of order $\{\mathcal{O}(\Delta r^2), \mathcal{O}(\epsilon \Delta t)\}$.² An important feature of the resulting algorithm (which we shall call DA) is its dissipative features, which make it particularly useful. The stability properties of this algorithm can be easily obtained by introducing Fourier modes such that $g = e^{su} e^{ikj/\Delta r}$. After some algebra one obtains

$$\begin{aligned} & S(i + 2\alpha \sin(k\Delta r/2) e^{-ik\Delta r/2}) \\ & = i \left((1 - \epsilon) + \frac{4}{3}\epsilon (4 \cos^2(k\Delta r/2) - 1) \right) - 2\alpha \sin(k\Delta r/2) e^{-ik\Delta r/2}, \end{aligned} \quad (13)$$

² Contrary to the Lax method which exhibits strict second-order convergence in space and time.

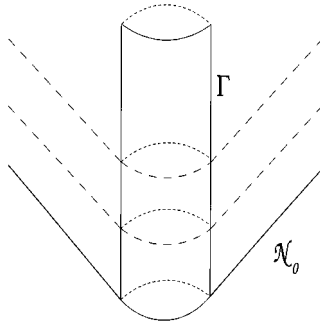

FIG. 2. The characteristic scheme for the exterior problem. Initial data is given on \mathcal{N}_0 and boundary data on Γ .

where $S \equiv e^{su}$ and $\alpha = \Delta u / (4\Delta r)$. Therefore, the equation governing the growth of the solution's modes is

$$|S|^2 = 1 + \frac{4\epsilon \sin^2(k\Delta r/2)}{3(1 - 4\alpha(1 - \alpha) \sin^2(k\Delta r/2))} (-2 + \sin^2(k\Delta r/2)(4\alpha + 4/3\epsilon)). \quad (14)$$

Now, since $4\alpha(1 - \alpha) \sin^2(k\Delta r/2) < 1$ (for $\alpha < 1/2$) the scheme will be stable if, $0 \leq \epsilon \leq 3/2(1 - 2\alpha)$. Moreover, $|S| < 1$ as $k \rightarrow \pi/\Delta r$, indicating that the high frequency modes are effectively “damped,” while $|S| \rightarrow 1$ as $k \rightarrow 0$.

The obtained discretization can also be thought of as an approximation to the original equation (3) (i.e., without the addition of the extra term), where the finite differencing of $g_{,ur}$ includes four points on the n th level as

$$\begin{aligned} g_{ur}|_{i-1/2}^{n+1/2} &= \frac{g_{,r}|_{i-1/2}^{n+1} - g_{,r}|_{i-1/2}^n}{\Delta u} \\ &= \frac{g_i^{n+1} - g_{i-1}^{n+1}}{\Delta u \Delta r} - \frac{(1 - \epsilon)(g_i^n - g_{i-1}^n) + \epsilon(g_{i+1}^n - g_{i-2}^n)/3}{\Delta u \Delta r}, \end{aligned} \quad (15)$$

which can be regarded as a weighted average of the derivatives at $(n, i - 1/2)$ obtained from field values at the points $\{(n, i), (n, i - 1)\}$ and $\{(n, i + 1), (n, i - 2)\}$. In the next section, we illustrate how this algorithm produces a stable discretization when the original strategy (corresponding to $\epsilon = 0$) fails.

III. APPLICATION IN A “TOY PROBLEM”

In this section we study the stability properties of an equation bearing close resemblance to the nonlinear evolution equation encountered in the characteristic formulation of general relativity (which will be presented in the Section IV),

$$2G_{,ur} - G_{,rr} = GG_{,u}G_{,r}. \quad (16)$$

In order to keep track of the nonlinearity of the equation, we introduce the parameter λ (with $\lambda \leq 1$), such that $G \equiv \lambda g$; hence, Eq. (16) becomes

$$2g_{,ur} - g_{,rr} = \lambda^2 g g_{,u} g_{,r}. \quad (17)$$

In particular, note that the principal part of Eq. (17) corresponds to the wave equation. Also, it reduces in the linear case ($\lambda^2 = 0$), to the wave equation. Consequently; one might expect the GIW discretization to lead a stable scheme.

However, this is not the case, as can be demonstrated by the following analysis. First, in order to simplify the study of the stability of this nonlinear problem, we *linearize the PDE with respect to the previous time step* [1] to obtain a more manageable equation. In this linearization, we approximate the values of g and g_r with respect to the n th level, but $g_{,u}$ is centered in between the levels. The resulting finite difference approximation is

$$\begin{aligned} & g_i^{n+1} - g_{i-1}^{n+1} - g_i^n + g_{i-1}^n + \frac{\Delta u}{4\Delta r} (-g_i^{n+1} + 2g_{i-1}^{n+1} - g_{i-2}^{n+1} - g_{i+2}^n + 2g_i^n - g_{i-1}^n) \\ & = \lambda^2 \frac{1}{8} (g_i^n + g_{i-1}^n) (g_i^n - g_{i-1}^n) (g_i^{n+1} + g_{i-1}^{n+1} - g_i^n - g_{i-1}^n). \end{aligned} \quad (18)$$

Finally, we introduce the Fourier modes $g = e^{su} e^{ikj\Delta r}$ and solve for $|S|^2$, obtaining

$$|S|^2 = 1 + \frac{16\alpha\lambda^2 \sin(K)^2 (1 + \cos(K))}{D}, \quad (19)$$

where $\alpha = \Delta u / (4\Delta r)$, $K = k\Delta r$, and

$$\begin{aligned} D \equiv & 16 + \lambda^4 (1 + \cos(K))^2 - 8\lambda^2 (\alpha \sin^2(K) + \cos(K) (1 + \cos(K))) \\ & + 32\alpha (1 - \alpha) (\cos(K) - 1). \end{aligned} \quad (20)$$

It is not difficult to check that D is a positive quantity for

$$0 < \alpha \leq \frac{1}{2} - \frac{\lambda^2}{8} + \frac{\sqrt{48 + \lambda^4 - 40\lambda^2}}{8} \quad (21)$$

(which will be the case if the CFL condition is satisfied). Thus, the value of $|S|$ is always larger than 1, indicating that this discretization is *unconditionally unstable*! It is remarkable that the simple addition of some nonlinear terms, even when they do not change the equation's principal part, completely break an algorithm that would otherwise be stable.

We now modify the way $g_{,ur}$ is discretized by introducing dissipation as dictated by the DA scheme, i.e.

$$g_{,ur} = \frac{1}{\Delta u \Delta r} (g_i^n - g_{i-1}^n - ((1 - \epsilon)g_i^n - g_{i-1}^n + \epsilon(g_{i+1}^n - g_{i-2}^n)) / 3). \quad (22)$$

With this simple modification, the value of $|S|^2$ now becomes

$$|S|^2 = 1 + \frac{4(\cos(K) - 1)N}{D}, \quad (23)$$

where

$$\begin{aligned} N = & -4\alpha\lambda^2 (1 + \cos(K))^2 + \epsilon(4 + \epsilon(\cos(K) - 1)) \\ & + \lambda^2 \cos(K)(\cos(K) + 1) + 4\alpha(\cos(K) - 1). \end{aligned} \quad (24)$$

Since $D > 0$ and $\cos(K) - 1 \leq 0$, the condition for stability is that $N \geq 0$. Given α , this is a condition on ϵ , or vice versa. For instance, if $\alpha = 1/8$ and $\lambda = 2^{-1/2}$, the discretization will be stable if $0.3 \leq \epsilon \leq 1$. On the other hand, if we choose $\lambda = 1$ and $\epsilon = 1/4$, $N \geq 0$ will be satisfied if $\alpha \leq \frac{1}{8}$. Figure 3 shows the value of $|S|$ for different choices of ϵ for a given λ ; the effect of the added dissipation can be clearly seen.

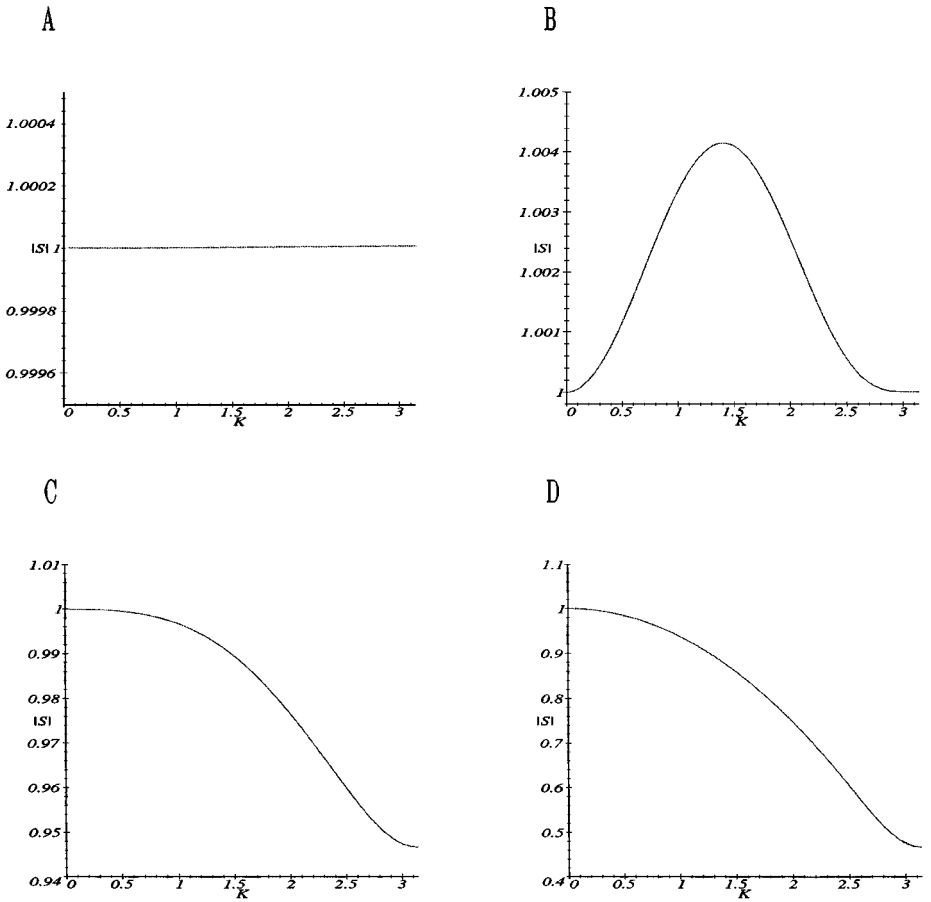

FIG. 3. Plots of $|S|$ corresponding to different choices of ϵ and λ . A ($\lambda=0$, $\epsilon=0$); B ($\lambda=0.02$, $\epsilon=0$); C ($\lambda=0.02$, $\epsilon=0.02$) and D ($\lambda=0.02$, $\epsilon=0.2$) which illustrates how adding artificial dissipation ensures stability. However, as can be seen in D for a high value of ϵ the damping of the high frequency modes might be severe.

IV. A PRACTICAL APPLICATION: THE CHARACTERISTIC FORMULATION OF G.R.

When solving Einstein equations, one can take advantage of the coordinate invariance of the theory to simplify the modeling of a specific problem. In particular, one is free to choose a foliation of the spacetime that is better suited to the problem.

In the numerical implementation of G.R., the most common approach is to choose a foliation by spacelike hypersurfaces at constant times. In this approach, Einstein equations form a second-order PDE system for the *intrinsic geometry* of each surface and its embedding in the spacetime, the *extrinsic curvature*. Einstein equations are split into two distinct sets of equations. One set consists of *constraint* equations that limit the possible configurations of the field variables on each hypersurface. The second set constitutes the *evolution* equations that determine the development of the field variables onto the next hypersurface.³

³ For a complete description of this formalism see [11].

The main drawback of the numerical implementation of the Cauchy formulation is the impossibility of having an infinite grid to completely cover the spacelike hypersurfaces. Thus, in practice, one chooses an exterior boundary in order to deal with a finite domain. This introduces further problems, since special conditions on the boundary must be imposed in order to avoid reflections which spoil long-term evolutions. Although in the one-dimensional case there are sound methods to achieve this (e.g., the Sommerfeld condition), in the general case, any local boundary condition still introduces reflections, turning the task of obtaining long accurate evolutions into an almost impossible one. A related problem arising from an outer boundary at a finite distance is that the radiation cannot be rigorously calculated.

When studying gravitational radiation a more natural choice adapted to the wave propagation is to adopt a sequence of characteristic hypersurfaces to cover the spacetime. This approach is known as the *characteristic formulation of G.R.*, pioneered by Bondi and Sachs [2, 3]. The main ingredients of this formulation are the foliation of the spacetime by a sequence of characteristic hypersurfaces and the use of compactification techniques (which enable the inclusion of infinity in a finite grid) to rigorously describe asymptotic properties of radiation [4]. The equations naturally split into *hypersurface equations* and *evolution equations*. We now outline the main aspects of the numerical implementation of this formulation (based on [7, 12], where a detailed description of the problem has been presented) and employ the constructed algorithm to discretize the PDE equations governing the evolution of the fields.

A coordinate system is introduced by labeling the outgoing lightlike hypersurfaces with a parameter u , each null ray on a specific hypersurface is labeled with x^A ($A = 2, 3$), and we choose r as a surface area coordinate (i.e., surfaces at $r = \text{const}$ have area $4\pi r^2$). In the resulting $x^a = (u, r, x^A)$ coordinates, the metric takes the Bondi–Sachs form [2, 3]

$$ds^2 = -(e^{2\beta} V/r - r^2 h_{AB} U^A U^B) du^2 - 2e^{2\beta} du dr - 2r^2 h_{AB} U^B du dx^A + r^2 h_{AB} dx^A dx^B, \quad (25)$$

where $h^{AB} h_{BC} = \delta_C^A$ and $\det(h_{AB}) = \det(q_{AB})$, with q_{AB} a unit sphere metric.

The metric components are re-expressed as

$$\begin{aligned} h_{22} &= \frac{4}{P^2} (\Re[J] + K), \\ h_{23} &= h_{32} = \frac{4}{P^2} \Im[J], \\ h_{33} &= \frac{4}{P^2} (K - \Re[J]), \\ U^2 &= \frac{P}{2} \Re[U], \\ U^3 &= \frac{P}{2} \Im[U], \end{aligned} \quad (26)$$

where $P = \sec^2(\theta/2)$ in standard angular spherical coordinates (θ, ϕ) . Here, the metric is expressed in terms of two real (β and V) and two complex (U and J) variables (where $K = \sqrt{1 + J\bar{J}}$). The complex field J measures the departure of spherical symmetry of the surfaces given by $r = \text{const}$ and $u = \text{const}$, V represents the mass distribution of the system, β measures the expansion of the light rays, and U measures the shift in the angular directions from one hypersurface to another (at constant r).

The hypersurface equations are expressed as

$$\beta_{,r} = F_\beta[J] \quad (27)$$

$$U_{,r} = F_U[\beta, J] \quad (28)$$

$$(r^2 Q)_{,r} = F_Q[U, \beta, J] \quad (29)$$

$$V_{,r} = F_V[Q, U, \beta, J], \quad (30)$$

where $Q \equiv r^2 e^{-2\beta} (J \bar{U}_{,r} + K U_{,r})$ which is introduced to deal with a first-order system of hypersurface equations. The functions F_β , F_U , F_Q , and F_V involve derivatives taken only on a particular hypersurface \mathcal{N} . Then, they can be easily integrated if J is known on \mathcal{N} (assuming consistent boundary conditions are provided) in the following way. The integration strategy proceeds by first obtaining β from Eq. (27), then U from Eq. (28), followed by the calculation of Q using Eq. (29), and finally, V using Eq. (30). The evolution to the next hypersurface is prescribed by a first-order (in time) equation for J that takes the form

$$2(rJ)_{,ur} - \frac{V}{r}(rJ)_{,rr} = rJ \left(\frac{J_{,u}}{K} (\bar{J}_{,r} K - \bar{J} K_{,r}) + \text{c.c.} \right) + F_J[V, Q, U, \beta, J], \quad (31)$$

where F_J involve derivatives on \mathcal{N} only.

A code that implements Einstein equations was written using (second-order) finite difference approximations. Angular and radial derivatives are approximated along the following lines [12]:

- *Angular derivatives.* We follow the formalism given in [13, 14]. To expedite the numerical implementation of angular derivatives, instead of working with the standard spherical angular coordinates (θ, ϕ) , we work in stereographic coordinates,

$$x^A = (q, p) = (\tan(\theta/2) \cos(\phi), \tan(\theta/2) \sin(\phi)), \quad (32)$$

and angular derivatives are written in terms of the (complex differential) e th operators and [15, 16]; for instance,

$$\frac{\partial \beta}{\partial q} = \frac{\beta + \bar{\beta}}{P}. \quad (33)$$

This allows us to employ a set of numerical techniques introduced in [17] which are specially tailored to: (i) handle the numerical approximation of angular derivative operators and (ii) deal with the fact that a single coordinate patch cannot be used to smoothly cover the sphere.

- *Radial derivatives.* These are approximated via centered second-order differences along each null ray (i.e., holding $x^A = \text{const}$); for instance,

$$\beta_i^n = \beta_{i-1}^n + \Delta r F_\beta|_{i-1/2}^n. \quad (34)$$

The evolution equation deserves special consideration. Its discretization (in between levels n and $n+1$) is obtained using dissipation in the following way: schematically, it can be re-expressed as

$$2g_{,ur} - (V/r)g_{,rr} = \frac{g}{r^2} (\bar{g}_{,u} g_{,r} + \text{c.c.}) + F_J[\beta, J, U, V], \quad (35)$$

where $g \equiv rJ$. The function F_J can be straightforwardly approximated at each grid point $(n + 1/2, i - 1/2)$ to second-order accuracy. Then, in order to introduce dissipation in the algorithm, we proceed to consider a modified version (along the lines described in Section II),

$$2g_{,ur} - (V/r)g_{,rr} = \frac{g}{r^2}(\bar{g}_{,u}g_{,r} + \text{c.c.}) + F_J(\beta, J, U, V) + \epsilon \frac{\Delta r^2}{\Delta u} g_{,rrr}. \quad (36)$$

We center the derivatives at the point $(n + 1/2, i - 1/2)$, as dictated by the DA scheme and obtain $g_{,u}|_{i-1/2}^{n+1/2}$ by means of an iterative procedure. In the first iteration we set $g_{,u} = g_{,u}|_{i-1}^{n+1/2}$ and get a first approximation of g_i^{n+1} via the evolution equation. Then, we use this value to obtain a guess for $g_{,u}|_{i-1/2}^{n+1/2}$ which is then used to get a better approximation for g_i^{n+1} . This procedure is repeated a sufficient number of times to ensure convergence.

Unfortunately, when solving a three-dimensional problem, the computational requirements of integrating from the origin ($r = 0$) are formidable. However, it is possible to start the integration from a finite value of r , assuming consistent values of β, U, Q, V , and J are known on this boundary (which is referred to as the worldtube boundary), as well as the value of J on an initial hypersurface [18].

To illustrate the usefulness of the presented algorithm, we apply it to model (i) the propagation of linear waves on a Minkowski background and (ii) the problem of scattering off a Schwarzschild black hole in three dimensions.

A. Linear Waves on a Minkowski Background

In the past, analytical solutions of linearized Einstein equations (in the characteristic formulation) have been found which describe waves propagating on a flat background [7]. These solutions provide an important test bed for the algorithm, since the numerically obtained solutions must converge to the analytic values given by

$$\beta = 0, \quad V = r \quad (37)$$

with J and U obtained from a solution (Ψ) of the scalar wave equation by

$$J_{,r} = \frac{(r^2 \ ^2\Psi)_{,r}}{2r^2}, \quad (38)$$

$$U_{,r} = -2 \frac{(\Psi + 2\Psi)}{r^2}. \quad (39)$$

In order to test the algorithm, we choose a solution of the wave equation in three dimensions that represents an outgoing wave with angular momentum $0 \leq l \leq 6$ of the form

$$\Phi = (\partial_z)^6 \frac{\alpha}{u^2 r}, \quad (40)$$

where ∂_z is the z -translation operator. The resulting solution is well behaved above the singular light cone $u = 0$.

Choosing initial data of very small amplitude ($\alpha \approx 10^{-9}$), we used these solutions to give data at $u = 1$ (with the inner boundary set at $R = 1.5$) and compared the numerical and exact solutions over time for different values of ϵ . The computation was performed on grids

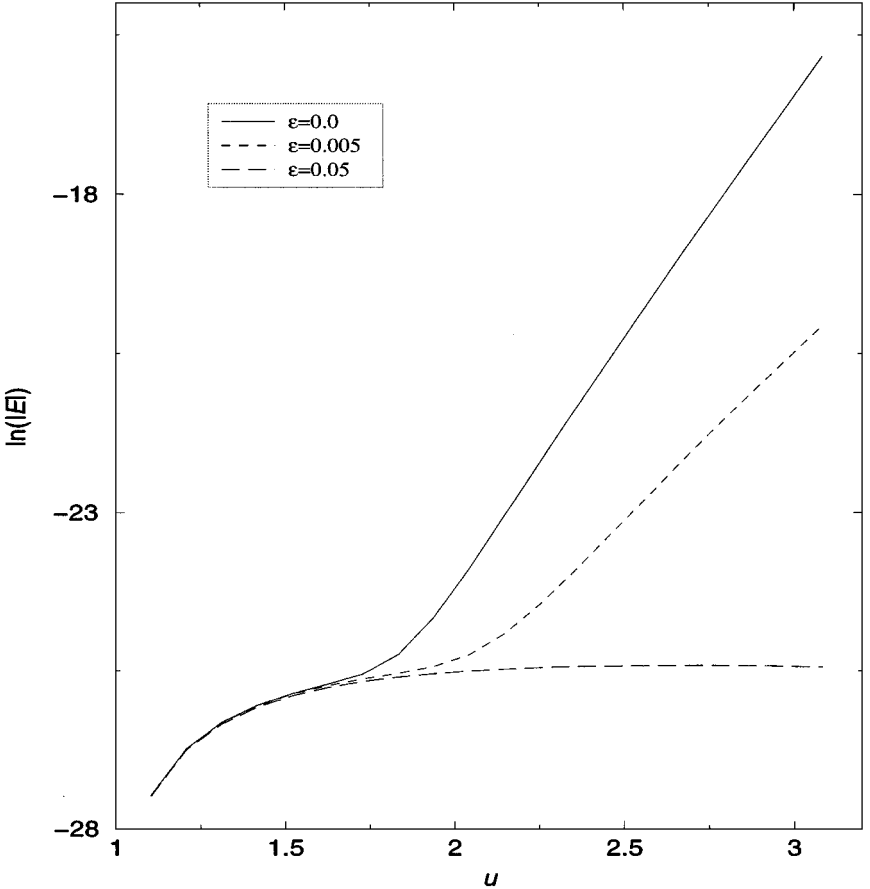

FIG. 4. The logarithm of $|E| \equiv |J^{\text{num}} - J^{\text{anal}}|$ (the numerical and analytic values of J) is shown for different values of ϵ . For $\epsilon = 0.05$ the evolution is stable, as opposed to the unstable evolutions correspondent to $\epsilon = 0$ and 0.005 .

of size N_x equal to 41, 53, 65 (with the number of angular points $N_\xi = (N_x - 1)/2 + 5$, and the ratio $\Delta u/(4\Delta r) = 1/8$). The L_2 norm of the error was calculated over the entire grid and plotted against time for different values of the dissipation parameter. Figure 4 shows the logarithm of the error in J versus time (for runs with $N_x = 65$). For $\epsilon = 0$ the evolution is unstable, as can be seen by the exponential growth of the error. For $\epsilon = 0.005$ the instability appears at a later time, also with an exponential growth. However, for $\epsilon = 0.05$ the run proceeds stably and the error remains under control. It is important to note that the magnitude of the dissipation needed to achieve a stable run is very small and therefore the “damping” of the solution is not severe.

B. Nonlinear Scattering Off a Schwarzschild Black Hole

The characteristic initial value problem on an outgoing null hypersurface requires inner boundary conditions on the worldtube. Here we consider an example in which the inner boundary Γ consists of an ingoing nullcone (see Fig. 5). We adopt coordinates x^A which follow the ingoing null geodesics and foliate Γ (chosen to correspond to ingoing $r = 2m$ surface in a Schwarzschild spacetime) by slices separated by constant parameter u . In these

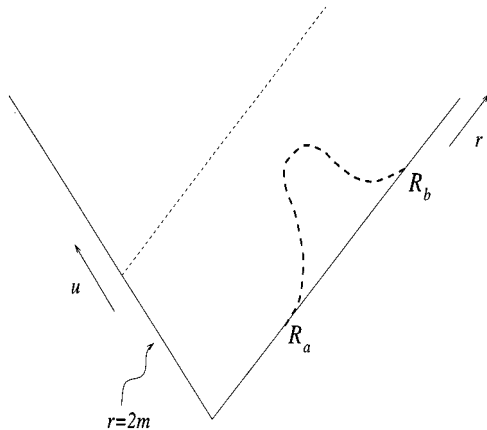

FIG. 5. Scattering off a Schwarzschild black hole. The bold dashed line illustrates the incoming pulse.

coordinates, the Schwarzschild line element takes the form

$$ds^2 = -\left(1 - \frac{2m}{r}\right) du^2 - 2 du dr + r^2 q_{AB} dx^A dx^B. \quad (41)$$

The initial data correspond to setting $J = 0$ as data on $u = 0$, with the boundary conditions $\beta = U = Q = 0$ and $V = r - 2m$ on Γ .

We pose the nonlinear problem of gravitational wave scattering off a Schwarzschild black hole by retaining these boundary conditions on Γ , but we choose null data at $u = 0$ corresponding to an incoming pulse with compact support,⁴

$$J(u = 0, r, x^A) = \begin{cases} \lambda \left(1 - \frac{R_a}{r}\right)^4 \left(1 - \frac{R_b}{r}\right)^4 \sqrt{\frac{4\pi}{2l+1}} {}_2Y_{l,m}, & \text{if } r \in [R_a, R_b] \\ 0, & \text{otherwise,} \end{cases} \quad (42)$$

where ${}_2Y_{l,m}$ is the spin-two spherical harmonic [15].

The code was run for different values of λ under different choices of the dissipation parameter. In all cases, unstable evolutions resulted from the choice $\epsilon = 0$; however, for nonzero values of ϵ , the code ran without any stability problem, as illustrated in Fig. 6 (for a run where $\lambda = 1, l = 2, m = 0$).

Yet, as expected of any dissipative algorithm, the solution decreases in amplitude with time. This highlights the need to carefully tune the value of ϵ . Notwithstanding this fact, it is important to stress once again that this set of runs would not have been possible without dissipation.

This problem was originally studied in the perturbative regime by Price [19]. There is no known analytic solution to the problem in the nonlinear regime and applying numerical methods is the only way to study it. The accuracy of the dissipative scheme can be assessed indirectly by inspection of the gravitational waves produced by the system. Gravitational waves can be described in terms of two *polarization modes* (referred to as *plus* and *cross*

⁴ Recall that the data on the initial hypersurface can be chosen freely in the characteristic formulation [5].

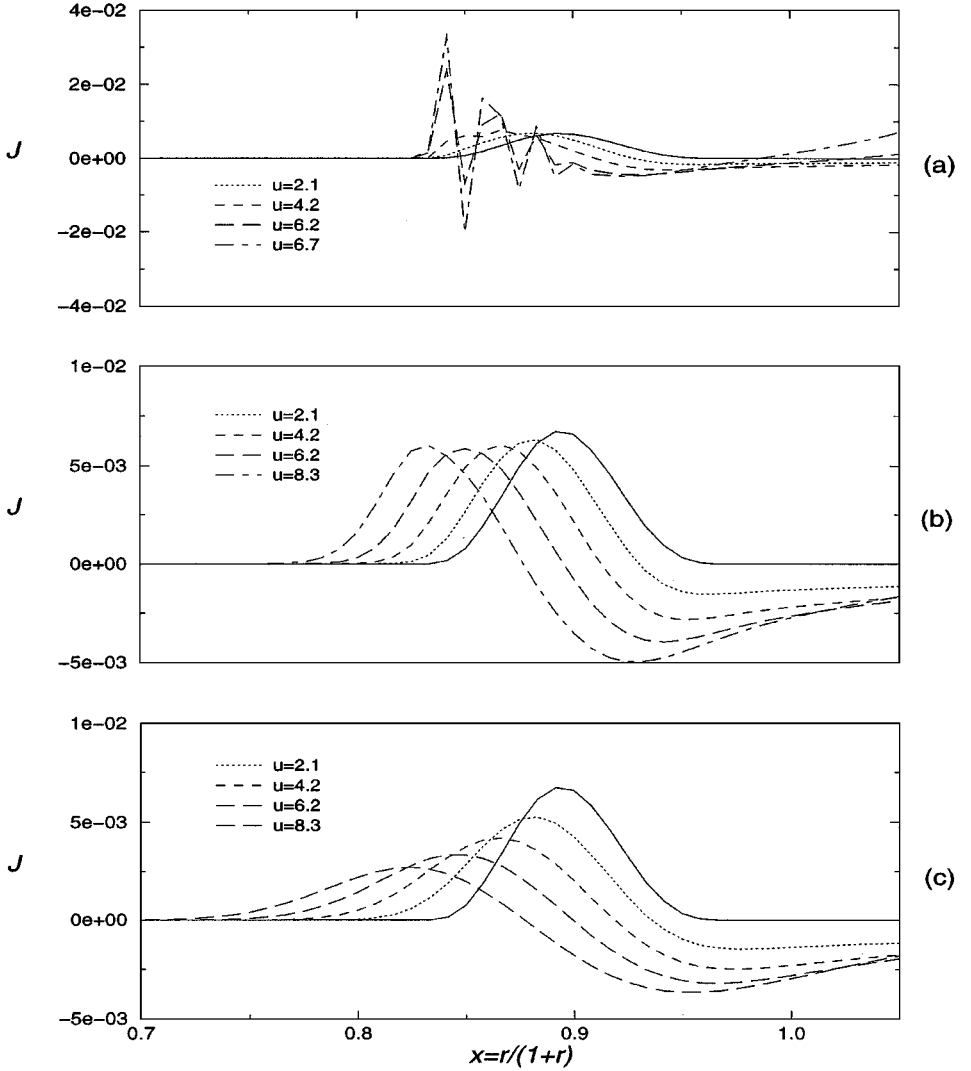

FIG. 6. Plots of the field variable J at a representative angle vs a compactified radial coordinate $x = r/(1+r)$. The value of the mass is $m = 0.5$, the amplitude of the initial pulse is $\lambda = 5$, $R_a = 4$, and $R_b = 8$. The runs correspond to different choices of ϵ . The solid lines indicates the initial data at $u = 1$. (a) shows the run for $\epsilon = 0$; after a short time the obtained values diverge. (b) corresponds to the choice $\epsilon = 0.005$, showing a run that neither show signs of instability nor much damping of the pulse. (c), in turn, corresponds to $\epsilon = 0.02$, although there is no sign of instability the solution has been damped considerably.

modes) [11]. However, when considering spacetimes with axisymmetry, the cross mode must vanish and this fact can be used to test the algorithm. Calculating the gravitational radiation is a rather involved problem that exceeds the scope of this work. A set of algorithms to numerically calculate the gravitational wave forms was constructed in the characteristic formulation in [12] and tested under different situations. We used these algorithms in the present work to calculate the polarization modes for the choice $\epsilon = \Delta r$ and with an axisymmetric pulse with $l = 2$, $m = 0$ as the initial data. The cross polarization mode actually converges to zero in second order, indicating an accurate discretization of Einstein equations, as can be seen in Fig. 7.

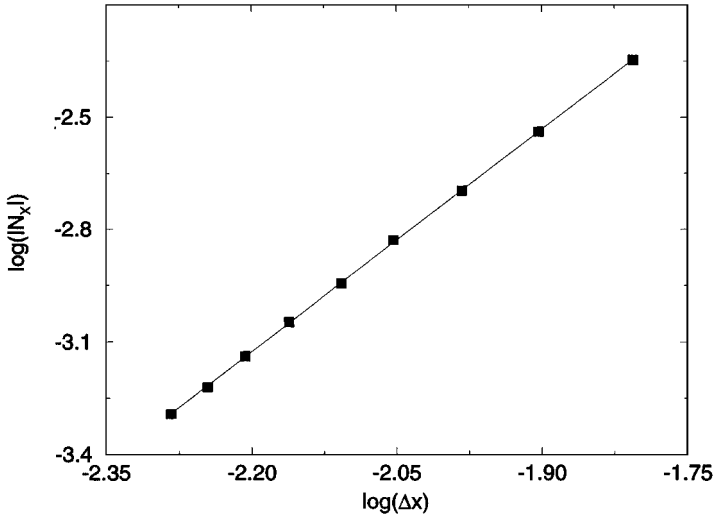

FIG. 7. Convergence of the cross polarization mode to zero (in these runs ϵ was chosen equal to Δr). The slope is 1.99, confirming second-order accuracy of the obtained wave form.

V. CONCLUSION

The algorithm described in this work represents a valuable tool for the study of non-linear problems in the characteristic formulation. Its use enables long-term evolution that would otherwise be impossible. Yet, there is still much room for improvement as the number of numerical techniques adapted to characteristic-type evolutions is scarce (as opposed to the situation in the Cauchy-type evolution, where one has at hand a great number of algorithms). The variety of physical problems, where propagating waves are to be described, highlights the need of further investigations on “characteristic” algorithms.

Of particular interest is the application of these types of algorithms to the characteristic module constructed to model the collision of a binary black hole self-gravitating system. In this problem, it is imperative to have robust enough schemes capable of dealing with highly nonlinear fields. The complexity of the problem inspired the creation of the Binary Black Hole Grand Challenge Alliance, where a group of U.S. universities and outside collaborators are joining efforts to tackle the problem [20]. A strategy to study this problem is a “hybrid” scheme that implements at the same time a Cauchy evolution (for the region near the black holes) and a characteristic evolution (for the exterior region). This approach is called *Cauchy–characteristic matching (CCM)* [21, 22, 8], and in principle, its implementation manages to avoid the problems and to exploit the best features of each evolution scheme. CCM has been shown to work (and outperform traditional outer boundary conditions) in situations where special symmetries were assumed [23, 10] and its full three-dimensional application in G.R. is currently under study. The characteristic code is one of the pieces of this bigger algorithm and the need for robust performance prompted this investigation. However, its use is not limited to G.R. Any hyperbolic system describing waves will have an evolution equation similar to Eq. (3). The algorithm presented in this work should provide a useful tool in the numerical modeling of these systems.

ACKNOWLEDGMENTS

This work has been supported in part by the Andrew Mellon Fellowship, by the NSF Grants PHY 9510895 and NSF INT 9515257 to the University of Pittsburgh and by the Binary Black Hole Grand Challenge Alliance, NSF Grant PHY/ASC 9318152 (ARPA supplemented). The author thanks Jeffrey Winicour, Roberto Gómez, and Nigel Bishop for valuable suggestions and also the Universities of South Africa and of Durban-Westville for their hospitality in completing part of this work. Computer time for this project has been provided by the Pittsburgh Supercomputing Center under Grant PHY860023P.

REFERENCES

1. J. Thomas, *Numerical Partial Differential Equations* (Springer-Verlag, New York, 1995).
2. H. Bondi, M. J. G. van der Burg, and A. W. K. Metzner, Gravitational waves in general relativity. VII. Waves from axis-symmetric isolated systems, *Proc. R. Soc. Lond. A* **269**, 21 (1962).
3. R. Sachs, Gravitational waves in general relativity. VIII. Waves in asymptotically flat spacetimes, *Proc. R. Soc. A* **270**, 103 (1962).
4. R. Penrose, Asymptotic properties of fields and space-times, *Phys. Rev. Lett.* **10**, 66 (1963).
5. J. Winicour, Characteristic evolution with matching, *Living Rev.* (1998).
6. R. Gómez, P. Papadopoulos, and J. Winicour, Null cone evolution of axisymmetric vacuum space-times, *J. Math. Phys.* **35**, 4184 (1994).
7. N. T. Bishop, R. Gómez, L. Lehner, and J. Winicour, Cauchy characteristic extraction in numerical relativity, *Phys. Rev. D* **54**, 6153 (1996).
8. R. d’Inverno and J. Vickers, Combining Cauchy and characteristic codes. IV. The characteristic field equations in axial symmetry, *Phys. Rev. D* **56**, 772 (1997).
9. R. Gómez, J. Winicour, and R. Isaacson, Evolution of scalar fields from characteristic data *J. Comput. Phys.* **98**, 11 (1992).
10. R. Gómez, R. L. Marsa, and J. Winicour, Black hole excision with matching, *Phys. Rev. D* **56**, 6310 (1997).
11. C. Misner, K. S. Thorne, and J. Wheeler, *Gravitation* (Freeman, San Francisco, 1973).
12. N. T. Bishop, R. Gómez, L. Lehner, M. Maharaj, and J. Winicour, High powered gravitational news, *Phys. Rev. D* **56**, 6298 (1997).
13. J. Winicour, Newtonian gravity on the null cone, *J. Math. Phys.* **24**, 1193 (1983).
14. J. Winicour, Null infinity from a quasi-Newtonian view, *J. Math. Phys.* **25**, 2506 (1984).
15. J. N. Goldberg, A. Macfarlane, E. Newman, F. Rohrlich, and E. Sudarshan, Spin-s spherical harmonics and eth, *J. Math. Phys.* **8**, 2155 (1967).
16. E. Newman and R. Penrose, Note on the Bondi–Metzner–Sachs group, *J. Math. Phys.* **7**, 863 (1966).
17. R. Gómez, L. Lehner, P. Papadopoulos, and J. Winicour, The eth formalism in numerical relativity, *Class. Quant. Grav.* **14**, 977 (1997).
18. L. Tamburino and J. Winicour, Gravitational fields in finite and conformal Bondi frames, *Phys. Rev.* **150**, 1039 (1966).
19. R. H. Price, Nonspherical perturbations of relativistic gravitational collapse. I. Scalar and gravitational perturbations, *Phys. Rev. D* **5**, 2419 (1972).
20. For information about the goals and status of the Alliance visit: <http://www.npac.syr.edu/projects/bh/>.
21. N. Bishop, Some aspects of the characteristic initial value problem in numerical relativity, in *Approaches to Numerical Relativity*, edited by R. d’Inverno (Cambridge Univ. Press, Cambridge, 1992).
22. N. Bishop, R. Gómez, R. A. Isaacson, L. Lehner, B. Szilagy, and J. Winicour, *Cauchy Characteristic Matching* (Kluwer, Dordrecht, 1998).
23. N. Bishop, R. Gómez, P. Holvorcem, R. Metzner, P. Papadopoulos, and J. Winicour, Cauchy–characteristic evolution and waveforms, *J. Comput. Phys.* **136**, 140 (1997).